

TURNING A POTPOURRI JAR LID



Glass jars make handy containers for candies, bath salts, candles and potpourri and when it is fitted with a nicely turned lid, it transforms a common glass container into a very elegant piece to display in the home. In this demonstration, I will describe how to turn a two piece lid for a potpourri container; aroma therapy is quite the rage these days. Glass food jars with screw/twist-off lids are the best and are made in a number of different sizes. Jelly jars with 2-7/8" diameter lids are a convenient size.



I make most of my lids from end grain mesquite, but many other species are ok as long as they are dry and relatively stable. The two pieces that make up the lid and their sizes are illustrated in the diagram below.

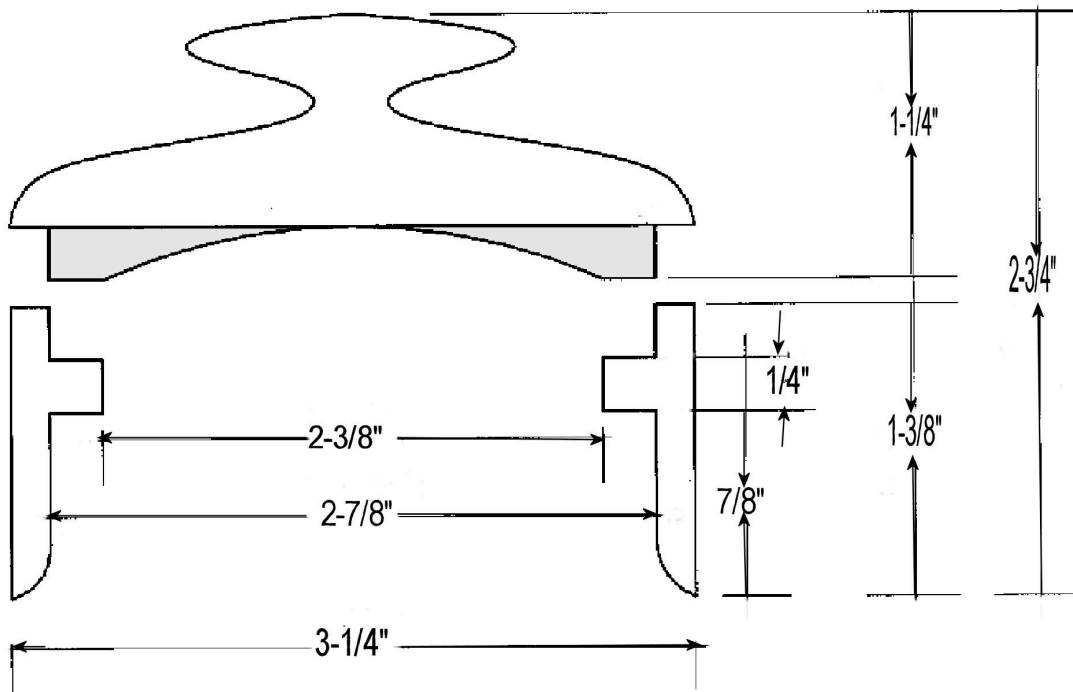

Diagram 1

Between centers, turn a 3-3/8" square by 3-1/4" long block to a finished diameter of 3-1/4". Turn a tenon at one end to fit your scroll chuck.



Mount the blank in your scroll chuck and using a 2-7/8" Forstner bit mounted in the tail stock, drill out a 7/8" deep hole. If you don't have a Forstner bit this large, just scribe a 2-7/8" circle on the end of the blank and use your gouge and flat scraper to make the 7/8" deep hole.



Change the 2-7/8" bit with a smaller 2-3/8" bit and counter drill a 5/8" deep hole. As mentioned previously, you can use a gouge and scraper to achieve this step. I like to gently taper the inside bottom portion of the wall (see diagram above). This will lend a graceful look to the finished piece.



At this point, test fit the metal jar lid. It should fit easily into the hole. Allow a little clearance for subsequent shrinkage of the wood. If the metal lid is too tight, use a 1" flat scraper to refine the hole. You might want to grind the long side of the scraper to facilitate enlarging the sides of the hole.

Using a 1/16" parting tool, separate the lid bottom at the 1-3/8" mark.



Remove and set aside the lid portion from the chuck and reverse chuck the bottom in an expansion mode. Take care not to over tighten the chuck as excess pressure will crack the thin wall of the piece. Several layers of reinforced box tape will reinforce the walls.



Use a bowl gouge and a bedan to remove the center portion of the lid and fashion the ledge. Diagram 1 above illustrates the "x" ledge to support the metal lid and screen.

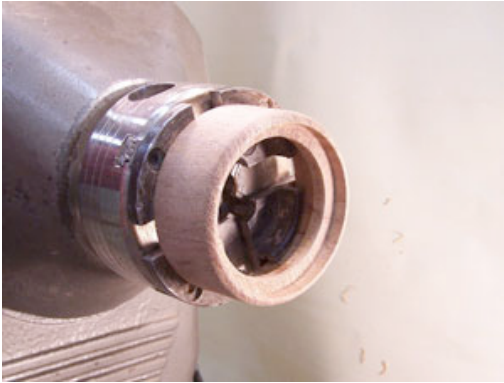

Remove the base and remount the lid portion. Cut the lip to match the top of the lid base as illustrated in the diagram above. Try for a relatively tight fit as you will finish the top using the base as a jam chuck. Relieve the underside of the top to remove some of the excess wood and make the top lighter.



Remove the lid and mount the base portion with the top portion facing you. Careful with the expansion force. Friction fit the lid to the base. If the fit is not tight enough, use paper toweling to increase the tightness of fit. Bring the tail stock and a live center to prevent dislodging the lid during shaping of the lid.

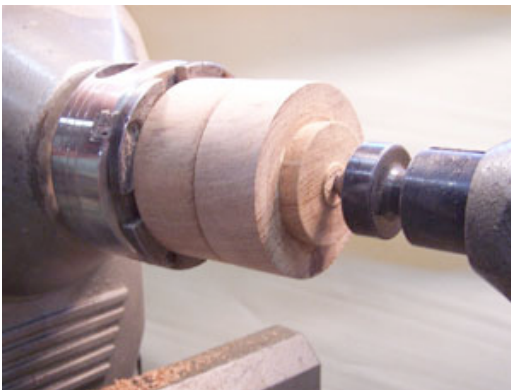

Shaping the lid is where your creativity and imagination can run free. In the photo below, I have turned a simple turned knob, but just about anything will work; inlaid wood, inlaid stone, Inlaid, whatever you desire. I go to craft stores and take a look at their jewelry findings, feathers, copper, brass, beads, and mother-of-pearl items to grace the top of my lids.

While the lid is still fixed to the bottom portion, sand to 400 grit and apply finish of your choice. Remove the lid, if it fits real tight and you have trouble removing it, run a 3/8" dowel through the headstock and gently tap the bottom of the lid. Refine the base diameter so that the lid has a slight suction fit



The next thing we need to do is to modify the metal lid and make a metal mesh to fit into the base. Cut a 1/8" plywood backing plate to fit the inside diameter of the lid.



Insert the backing plate into the metal lid and mount in the scroll chuck using expansion. Using a skew or similar metal cutting tool, cut a 2-3/8" circle out of the middle of the lid. Use a flat scraper to remove the paint from the metal so the epoxy glue can bond to the metal surface

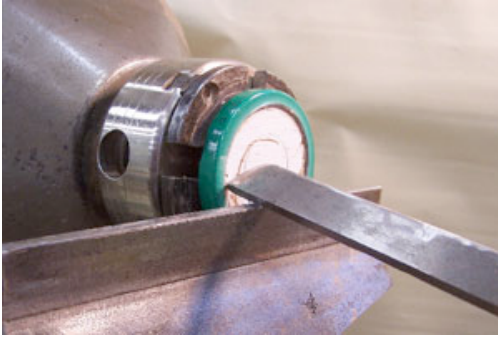

.Cut a circular expanded metal insert to fit the inside of the base. I use the expanded metal rain gutter guards (prevents leaves from clogging up your rain gutters). These inserts look nice if painted (gold is nice).

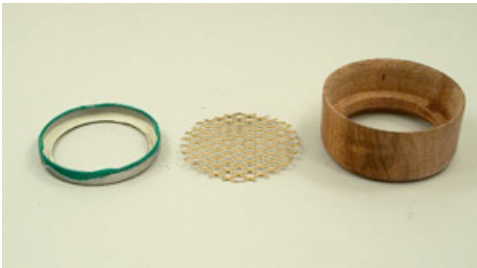

Put the expanded metal insert into the base. Mix some epoxy (I use 5 minute) and apply it to the sides of the base where the wood meets the metal insert. Put the metal jar lid on top of the insert and then screw it onto the glass jar. Put a weight on the lid to assure a close fit with the bottom of the ledge. Allow the glue to cure.



The photo below shows the finished lid.



As a variation on this theme, you can eliminate the lid and make a quick candy jar, candle container, etc.



If you have questions on this project, email me.

Joel Crabbe
jcrabbe@clearwire.net